

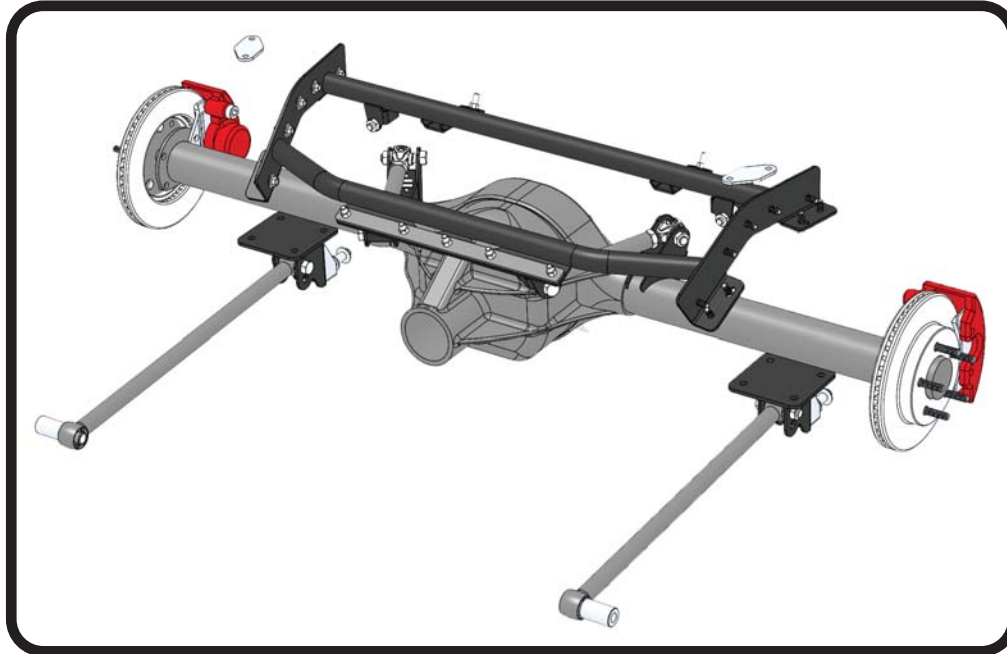

Part # 11167199 -1967-1969 GM "F" Body Rear R-Joint Bolt-in 4 Link

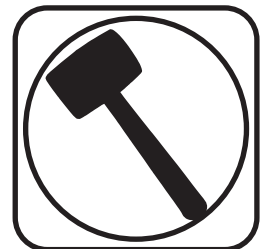

Recommended Tools

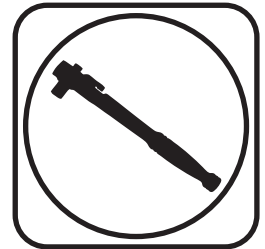

1967-1969 GM "F" Body Rear Bolt-in 4Link Installation Instructions

Table of contents

Page 2-3.....	Included Components
Page 4.....	Hardware List & Getting Started
Page 5.....	OEM Variation
Page 5-10....	Cradle Installation
Page 10.....	Lower Bar Installation
Page 11.....	Lower Bar & Shock Mount Installation
Page 12.....	Attaching Lower Shock Mount & Lower Bar
Page 13.....	Installing Lower Bar
Page 14.....	Setting Pinion Angle
Page 15.....	Upper Bar Axle Tab Installation
Page 16.....	Installing Axle Tabs
Page 17.....	Installing ShockWaves/CoilOvers & Shock Block Off





Major ComponentsIn the box

Item #	Part #	Description	QTY
1	90002722	Upper Cradle	1
2	90002723	Forward Tab Inner Brace	1
3	90001844	Trunk Reinforcement	2
4	90000523	Shock Block Off Plate	2
5	90002077	Lower Axle Mount - Driver	1
6	90002078	Lower Axle Mount - Passenger	1
7	90002819	Lower Bar Assembly - Driver - 25 1/16" center to center	2
8	70013537	Front R-Joint Spacer	2
9	90001318	RH R-Joint Threaded Housing End (installed in bars)	2
10	90002818	Upper Bar - 10.150" center to center	2
11	70013334	R-Joint Spacers	14
12	70013049	Inner Upper Bar Tab - Driver	1
13	70013050	Inner Upper Bar Tab - Passenger	1
14	70013051	Outer Upper Bar Tab	2
15	70013052	Axle Tab Rear Brace	2
16	90001624	Aluminum Lower Shock Mount	2
17	70002825	Lower Shock Stud	2
18	90002067	Lower Shock Spacers	4
	99752004	RH 3/4"-16 Jam Nut (installed on bar ends)	2
	85000008	Riv-Nut Installation Tool (NOT SHOWN)	1
	70010694	Bar Tab Setting Jig (NOT SHOWN)	2
	99371050	3/8"-16 x 1 1/2" Conical Body Bolt (NOT SHOWN)	6
	99372009	3/8"-16 U-Nut (NOT SHOWN)	6
R-Joint Components - (Installed in bar ends)			
	70013279	Retaining Ring	6
	70013280	Wavo Wave Spring	6
	70013275	R-Joint Center Ball	6
	70013276	R-Joint Composite Center Ball Cage	6

New R-Joints will be quite stiff (75-90 in/lbs breakaway torque) until they "break in" after a few miles of use. After the break in period they will move much more freely. Because the composite bearing race contains self lubricating ingredients, no additional lubrication is needed or desired. Any additional lubrication will only serve to attract more dirt and debris to the R-Joint and actually shorten its life.



Major ComponentsIn the box

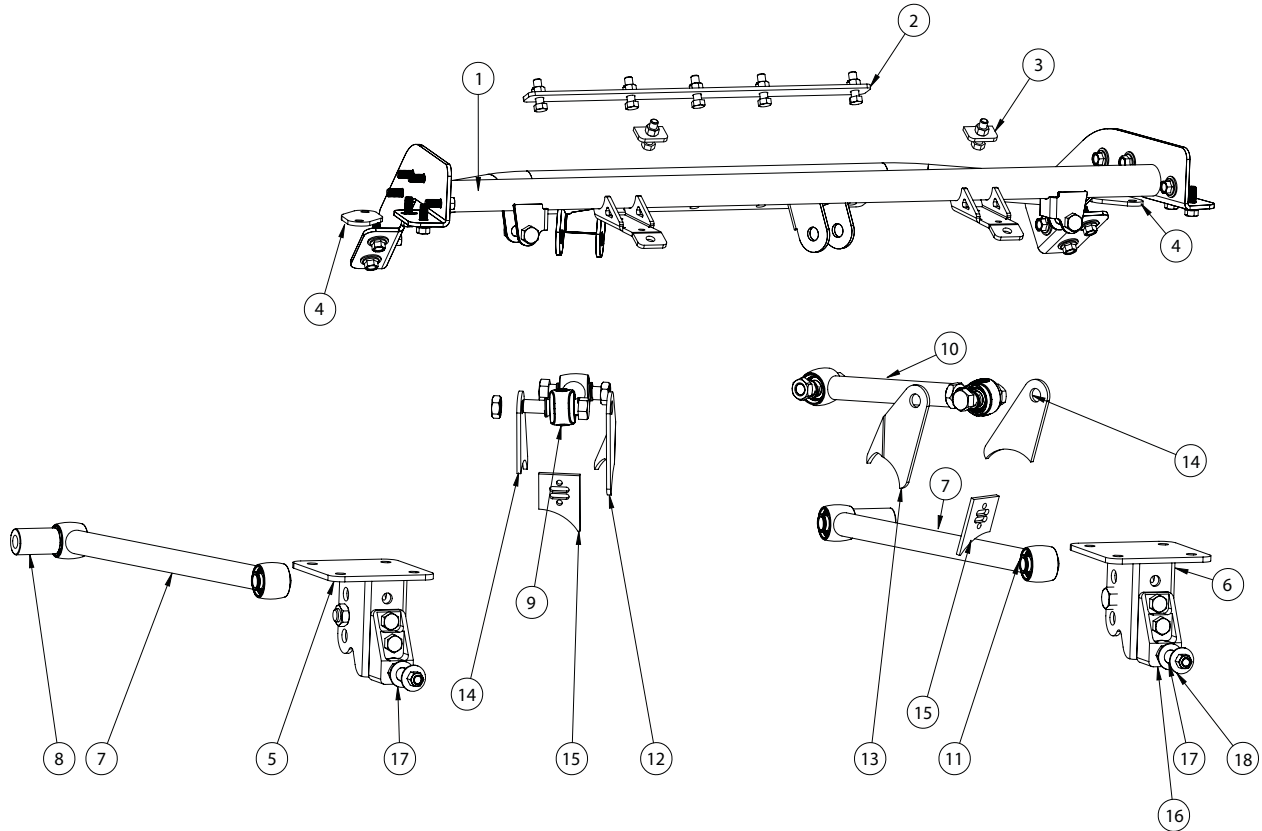

R-JOINT SPACER INSTALLATION

Install the Spacers by inserting the SMALL side of the SPACER into the Center Pivot Ball. Push them in until they bottom out and stop.

LOWER FRONT R-JOINT

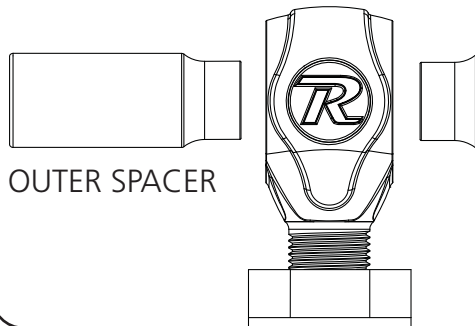

ALL OTHER R-JOINTS

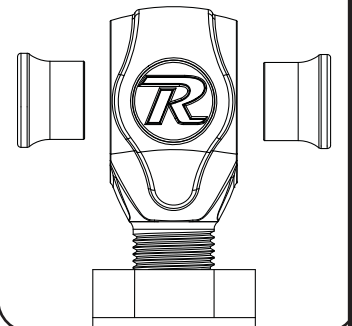

New R-Joints will be quite stiff (75-90 in/lbs breakaway torque) until they "break in" after a few miles of use. After the break in period they will move much more freely. Because the composite bearing race contains self lubricating ingredients, no additional lubrication is needed or desired. Any additional lubrication will only serve to attract more dirt and debris to the R-Joint and actually shorten its life.



Hardware ListIn the box (Kit# 99010197)

The Hardware Kit contains bags to help aid in selecting the correct hardware for the component being installed. The hardware list shows how the hardware is bagged.

QTY	Part Number	Description	QTY	Part Number	Description
CRADLE - FRONT TAB & SWAY BAR MOUNT			4 LINK BARS		
7	99371004	3/8"-16 x 1 1/4" Hex Bolt	6	99621004	5/8"-18 x 3" Gr. 8 Bolt
7	99372002	3/8-16" Nylok Nut	6	99622006	5/8"-18 Nylok Jam Nut
12	99373003	3/8" SAE Flat washer	12	99623010	5/8" SAE Flat Washer
CRADLE MOUNTING			SHOCK MOUNT & SHOCK MOUNTING		
18	99371005	3/8"-16 x 1 1/4" Bolt	2	99501026	1/2"-13 x 2 1/4" Hex Bolt
18	99372007	3/8"-16 Riv-Nut	2	99502007	1/2"-13 Thin Nylok Jam Nut
18	99373006	3/8" Split Lock Washer	2	99501019	1/2"-13 x 1 1/4" Hex Bolt
18	99373002	3/8" SAE Flat washer	2	99501046	1/2"-13 x 1 3/4" Hex Bolt
1	85000007	17/32" Drill Bit	4	99502001	1/2"-13 Nylok Nut
LOWER BAR MOUNT TO AXLE			LOWER BAR - FRONT MOUNTING		
8	99432007	7/16"-20 Nylok Nut	2	99621007	5/8"-18 x 5" Hex Bolt
LOWER BAR - FRONT MOUNTING			2	99622006	5/8"-18 Nylok Jam Nut
2	99621007	5/8"-18 x 5" Hex Bolt	4	99623001	5/8" Flat Washer
2	99622006	5/8"-18 Nylok Jam Nut	UPPER 4 LINK TAB SETTING JIG		
4	99623001	5/8" Flat Washer	2	99371001	3/8"-16 x 3/4" Hex Bolt
SHOCK STUD			2	99372004	3/8"-16 Hex Nut
2	99432002	7/16"-20 Nylok Nut			
2	99433002	7/16" SAE Flat Washer			
2	99623004	5/8" SAE Flat Washer			

Getting Started.....

Congratulations on your purchase of the Ridetech Rear 4-link System. This system has been designed to give your Camaro excellent handling along with a lifetime of enjoyment. This kit replaces the Leaf Springs, this allows the 4-Link to locate the rearend and the CoilOvers/ShockWaves to support the car. This allows each to be optimized for the best performance.

Note: These system is designed for use with the Ridetech Shockwaves or CoilOvers and the MuscleBar swaybar. **The factory shocks and springs will not fit this setup.**

1. Raise the vehicle to a safe and comfortable working height. Use jack stands to support the vehicle with the suspension hanging freely. You will need a method of raising and lowering the differential.
2. Support the axle and remove the leaf springs, shocks, and tail pipes. Refer to the factory service manual for proper disassembly procedures. Retain the front leaf spring mounts, they will be used with the 4 link. You may need to detach the fuel line from the frame rails. The back seat of the car will also need removed for installation of the 4 link cradle.



OEM Variation

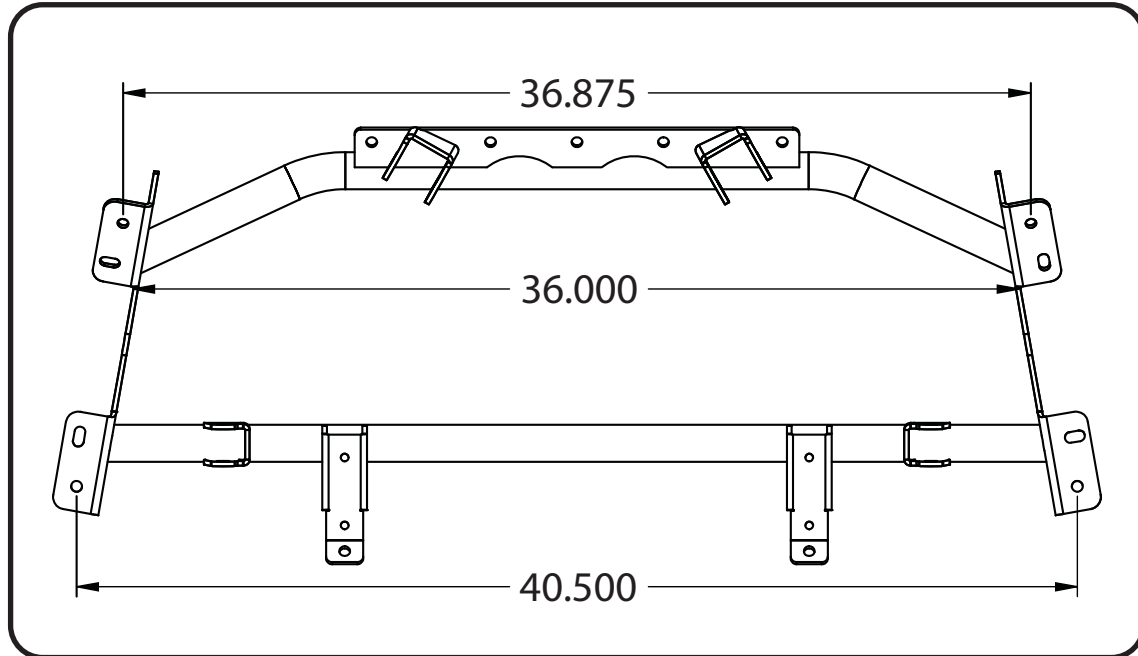

Note: In rare cases, the dimension from frame rail to frame rail on your F-Body may vary from the dimension on the Ridetech Upper Cradle. **ALL** of the Ridetech Upper Cradles are jig built to the dimensions above. The variation in OEM manufacturing specs does happen and is out of our control. If your F-Body frame rails seem out of spec, feel free to contact our Tech Department at 812-482-2932 and we will try to offer some solutions.

Cradle Installation

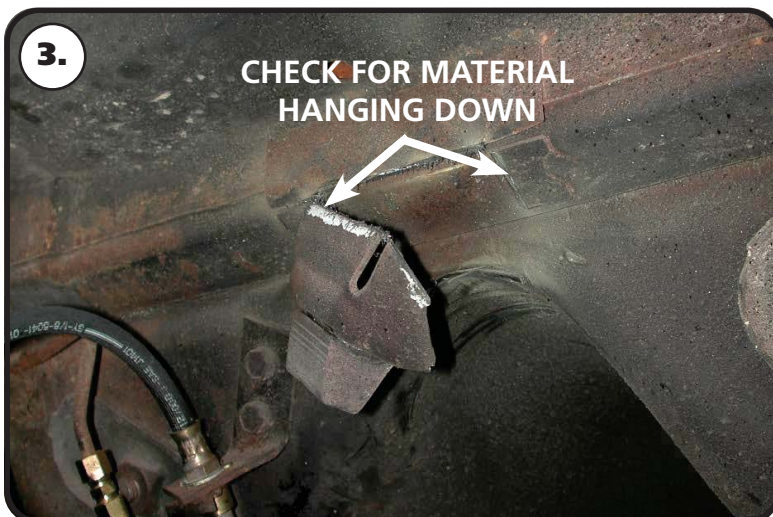

3. Remove the factory pinion snubber and mount from the car, this is necessary for clearance of the upper cradle. We use a cut off wheel to remove the mount. Make sure the area where the ARROW is pointing has no material sticking down. The tabs that are against the body can remain. Check both sides where the snubber mount attached to the body.



Cradle Installation



4. Steps 5-14 cover mounting the cradle into the car, review all steps. Image 4 shows the cradle installed in the car.

Note: The OEM fuel line will need to be detached from the frame rails until the cradle is installed.



5. Install the cradle into the car. When the cradle is positioned properly, the front bar should be up against the body, the front tab will be up against the bottom side of the seam, and the sway bar mount tabs should be up against the bottom of the trunk pan.

THE CRADLE WILL GET TEMPORARILY BOLTED IN BY THE FRONT TAB AND REAR SWAY BAR TABS. IT WILL GET REMOVED TO DRILL AND INSTALL THE RIV-NUTS IN THE FRAME RAILS.



6. **Image 6** shows how the front tab overlaps the body seam. Multiple pieces of the car body overlap at this joint making it a strong area to attach to. Drill these 5 holes with a 3/8" drill bit using the cradle as a template.



Cradle Installation



7. The kit includes a backing plate for the front tab. This backing plate is installed in the inside of the car. The rear seat will need removed for installation. Lay the backing plate on the seam, lining up the 5 holes drilled in the previous step. Install a 3/8" flat washer on each of (2) 3/8"-16 x 1 1/4" hex bolts. **Insert a bolt/washer in the 2 other holes from the BOTTOM with the threads pointing up.** Install a 3/8" flat washer followed by a 3/8"-16 nylok nut on threads of each of the bolts sticking through the backing plate.



8. Drill a 3/8" hole through the each of the sway bar mount tabs. These holes will go into the trunk so make sure nothing is in the trunk floor. If there is a mat, remove it before drilling the holes.

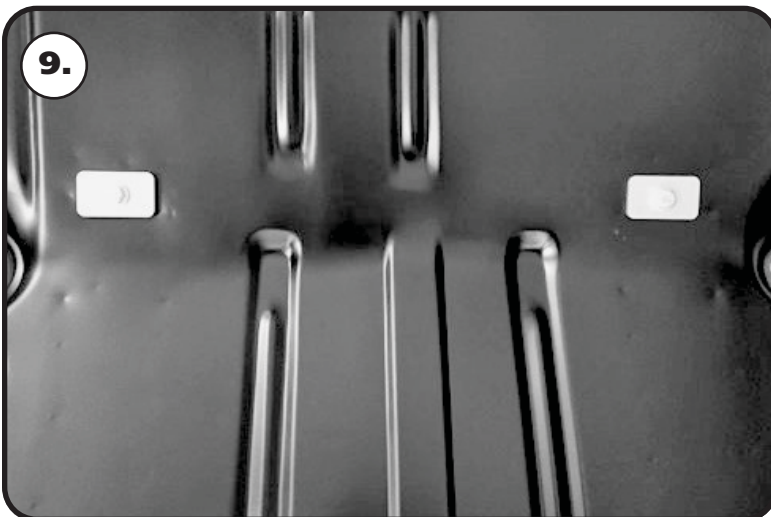

9. Image 9 shows the trunk backing plates installed in the trunk. Locate the backing plates in the trunk lining up the center hole with the hole drilled in the floor. Install a 3/8" flat washer on each of (2) 3/8"-16 x 1 1/4" hex bolts. Insert the bolt/washer through the backing plate, through the trunk floor and sway bar Tab with **the threads on the Bolt pointing DOWN.** Install a 3/8" flat washer followed by a 3/8"-16 nylok nut on the threads of the bolts sticking through the sway bar tab.



Riv-nut® Installation & Specs

1. Drill hole in frame using the SUPPLIED DRILL BIT keeping the drill square with the metal.
 2. We recommend installing (2) 3/8" flat washers between the bolt head and the lower anvil of the installation tool. Thread a Riv-nut® onto the supplied Tool. Thread the Riv-nut all the way onto the tool until it stops.
 3. Insert the tool and Riv-nut® into the drilled hole 90° to the frame rail.
 4. The tool requires (1) 9/16" & (1) 5/8" wrenches to use. A ratchet can be used on the top of the tool.
- KEEP THE TOOL AND RIV-NUT 90° TO THE SURFACE WHILE TIGHTENING**
5. Put a 5/8" wrench on the lower hex of the tool. Use a wrench or ratchet on the top hex to tighten.
 6. Hold the wrench in one position and turn the TOP HEX CLOCKWISE to engage the Riv-nut®. Keep turning the TOP WRENCH until you feel a positive stop and you can't turn the TOP WRENCH anymore.
 7. Break the tool loose by turning the TOP HEX counterclockwise and thread the tool out of the Riv-nut®

THE DATA BELOW ILLUSTRATES THE STRENGTH OF THE RIV-NUT®

RIVNUT® Fastener Engineering Data

Upset Load (lbs.)		
RIVNUT * Size	Steel	
	Min. Grip	Max. Grip
3/8-16	4965	5325

Fig. 1

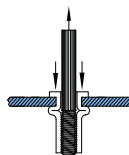

Ultimate thread strength (lbs.)		
RIVNUT * Size	Steel	
	Min. Grip	Max. Grip
3/8-16	11500	10450

Fig. 2

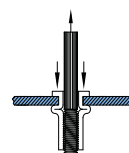

Ultimate tensile strength (lbs.)	
RIVNUT * Size	Steel
3/8-16	3900

Fig. 3

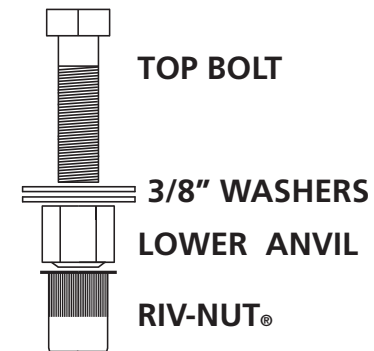
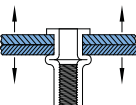

Figure 2

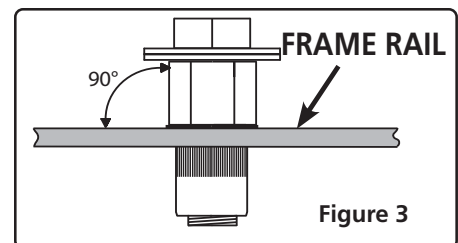

Figure 3

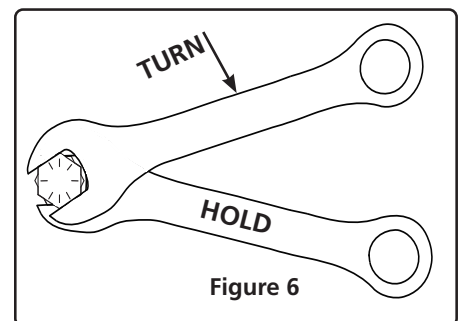

Figure 6

**Single Shear Strength 3/8" Grade 5 Bolt
3,975.8 lbs**



Cradle Installation



10. Mark the holes of the frame mounts. Mark the slotted holes in the center of the slot. These holes use Riv-nuts to bolt the cradle to the frame. The holes need to be centered as much as possible. Make sure to mark all (9) holes in each frame rail.



11. Remove the cradle to drill the holes and install the Riv-nuts. The holes for the Riv-nuts **NEED** to be drilled with the supplied 17/32" drill bit. We suggest drilling the holes with a smaller drill bit first to make it easier to drill with the 17/32" drill bit. Drill all (18) holes in the frame rails.



12. Install the Riv-nuts in the frame rails. **Refer to the Riv-nut installation instructions on PAGE 8 for proper Riv-nut installation.** **Image 12** illustrates a Riv-nut being installed. Install all (18) Riv-nuts in the frame rails.



Cradle Installation & Lower Bar Mount



13. After you get all the riv-nuts installed, reinstall the cradle in the car. The bolts for the front tab and sway bar mounts can be reinstalled. Leave everything loose until all the bolts are started.



14. Install a 3/8" split lock washer & 3/8" flat washer on each of the 3/8"-16 x 1 1/4" bolts supplied in the kit. Thread them into the riv-nuts. Torque to 23 ft-lbs. Torque the front tab and sway bar tab hardware to 30 ft-lbs.



15. The R-joint setup is designed to be offset to the inside of the car. The bolt hole in the mounting bracket has to be drilled out to 5/8" and the new 5/8" x 5" bolt, washers, & 5/8" thin nylok nut are used. The wider spacer is used on the outside with a narrow spacer on the inside. This will offset the bar to the inside of the car for better wheel and tire clearance. The bolt needs to go in the bracket like seen in the picture. The threads of the bolt must be pointing to the OUTSIDE of the car. Shown in **Image 15** is the driver side bar and mount. Repeat on both sides and tighten the bolts/nuts enough to eliminate any gaps.



Lower Bar & Shock Mount Installation



16. Attach the lower bar/mount assembly to the car. New 3/18"-16 u-nuts and 3/8-16" x 1 1/2" conical body Bolts are supplied in the kit. Install the u-nuts in place of the OEM u-nuts. Hold the assembly in place lining up the holes with the u-nuts. There is a tab bent up on the mount that indexes into a hole in the body. Make sure the tab is indexed into the alignment hole. Torque the mounting bolts to 30 ft-lbs.

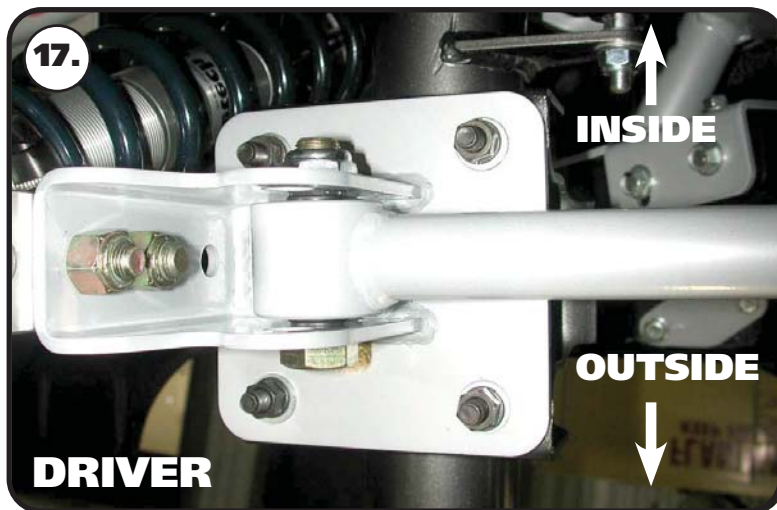

17. The lower axle bracket will be fastened to the leaf spring pad using the factory T-bolts/ U-bolts. The bar mount is offset to the inside of the car to provide more wheel and tire clearance. New 7/16" nyloks are supplied. Torque the nuts to 55 ftlbs.

Image 17 shows the Driver side.

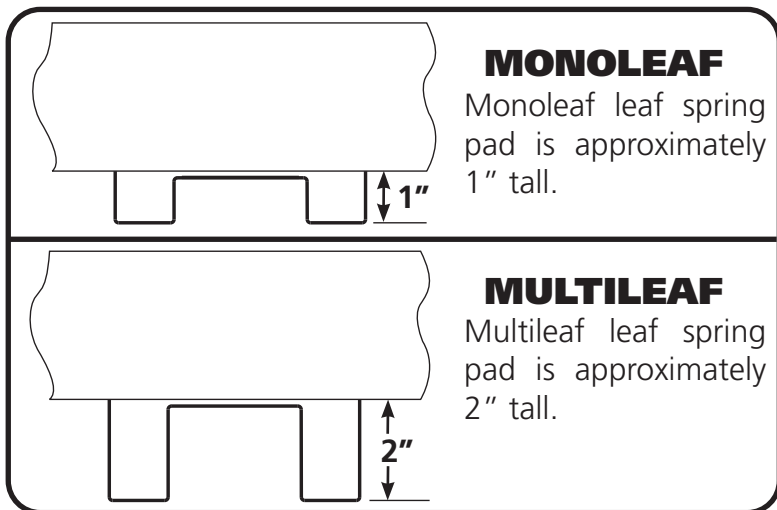

The 67-69 F-body could come with either a Monoleaf spring or Multileaf spring. We provided this guide to help you determine which leaf spring mount your car has. Steps 18 & 19 cover bolting the lower shock mount to the axle bracket. You need to know which leaf spring mounts you have to determine how the shock mount needs bolted to the axle mount. Image 18 shows the Multileaf, Image 19 covers the Monoleaf. The leaf spring mount on each of the rear differentials are different heights requiring the lower shock mount be attached in different locations depending on the leaf spring mount. The lower mount attaches with (1) 1/2"-13 x 1 1/4" hex bolt, (1) 1/2"-13 x 1 3/4" Hex Bolt, & (2) 1/2"-13 nylok nut.



Attaching Lower Shock Mount & Lower Bar

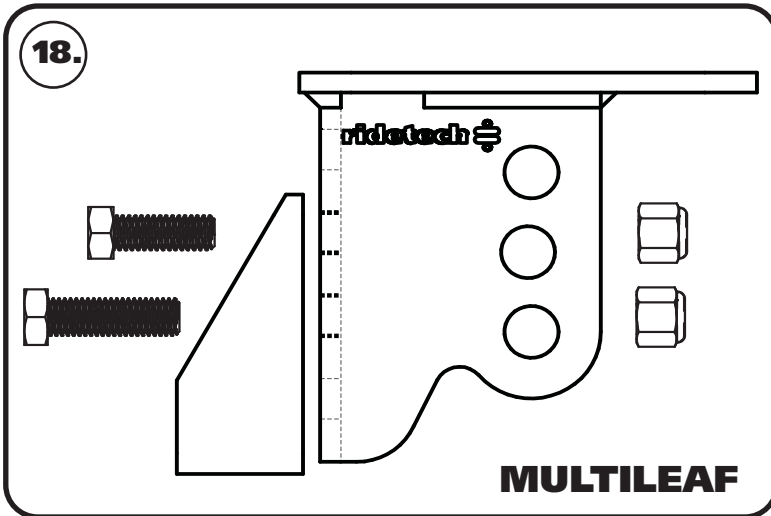

18. MULTILEAF - The Multileaf setup uses the **MIDDLE 2 HOLES** for mounting. Insert the bolts through the aluminum shock mount with the 1 1/4" long bolt in the top bolt, 1 3/4" in the bottom hole. Insert the bolts through the axle mount and install the nylok nuts on the threads sticking through. Repeat on both sides and torque the bolts/nuts to 75 ftlbs. Skip to **Step 20**.

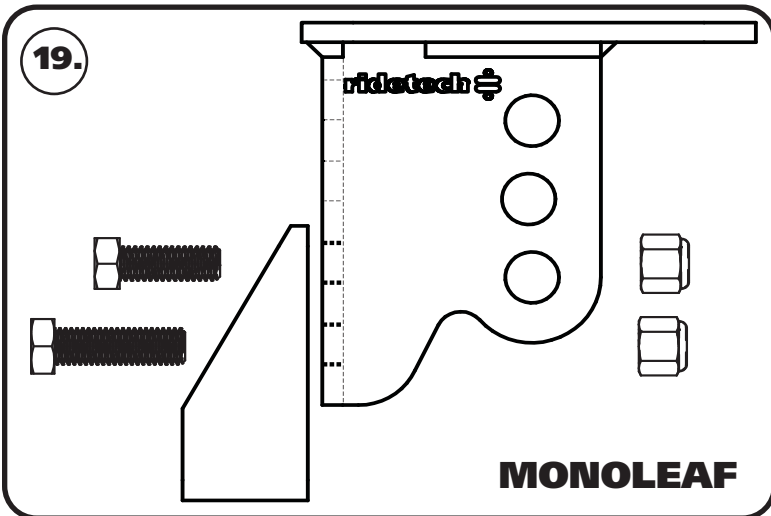

19. MONOLEAF - The Monoleaf setup uses the **BOTTOM 2 HOLES** for mounting. Insert the bolts through the aluminum shock mount with the 1 1/4" long bolt in the top bolt, 1 3/4" in the bottom hole. Insert the bolts through the axle mount and install the nylok nuts on the threads sticking through. Repeat on both sides and torque the bolts/nuts to 75 ftlbs.

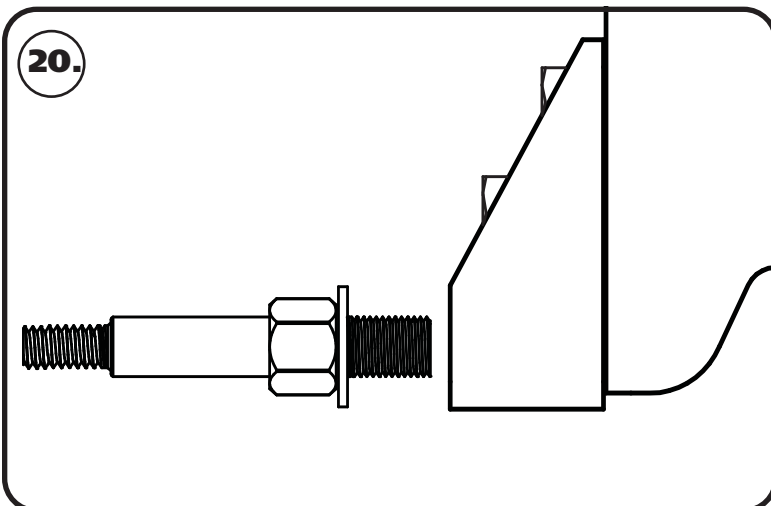

20. Installing the shock stud into the lower mount. Install a 5/8" flat washer onto the 5/8"-18 threads of the shock stud. Apply Red Loctite to the 5/8" threads of the stud. Thread the shock stud into the threaded hole of the lower mount. Repeat on both sides and torque the shock stud to 65-75 ftlbs.



Installing Lower Bar

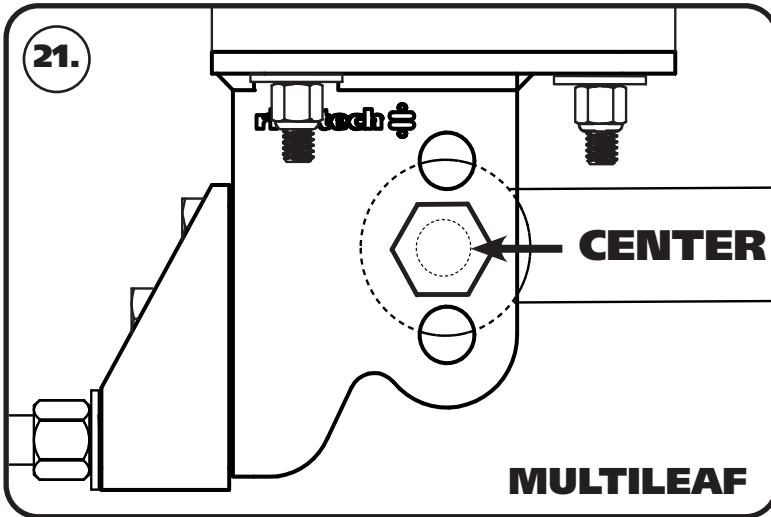

21. Images 21-23 illustrate attaching the lower bar to the axle mount. Image 21 shows the Multileaf, Image 22 covers the Monoleaf, Image 23 shows a bottom view. The different heights of the leaf spring pads of the differentials require the lower bars to be mounted in the correct hole to optimize the geometry of the 4 link bars. A 70013334 spacer will need to be installed on each side of the R-Joint with the SMALL OD inserted into the R-joint center ball. Use **Image 23** as a reference. The lower bar attaches with (1) 5/8"-18 x 3" hex bolt, (2) 5/8" flat washers, & (1) 5/8"-18 nylok jam nut. **MULTILEAF** - The Multileaf setup uses the MIDDLE HOLES for mounting. Insert the bar into the lower mount lining the bushing sleeve up with the CENTER set of holes. Insert a 5/8"-18 x 3" bolt into the hole/sleeve. Install a 5/8"-18 nylok jam nut on the bolt threads sticking out of the bracket. Repeat on both sides and tighten the bolts/nuts enough to eliminate any gaps. Skip to **Step 23**.

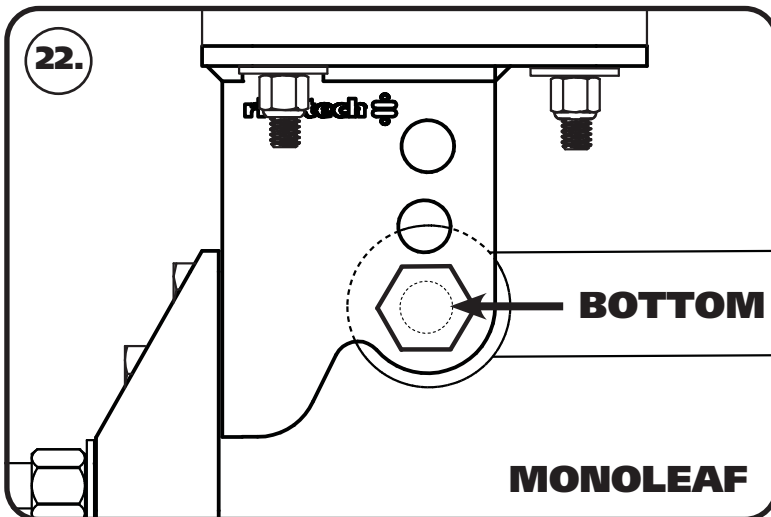

22. MONOLEAF - The Monoleaf setup uses the BOTTOM HOLES for mounting. Insert the bar into the lower mount lining the bushing Sleeve up with the BOTTOM set of holes. Insert a 5/8"-18 x 3" bolt into the hole/sleeve. Install a 5/8"-18 nylok jam nut on the bolt threads sticking out of the bracket. Repeat on both sides and tighten the bolts/nuts enough to eliminate any gaps.

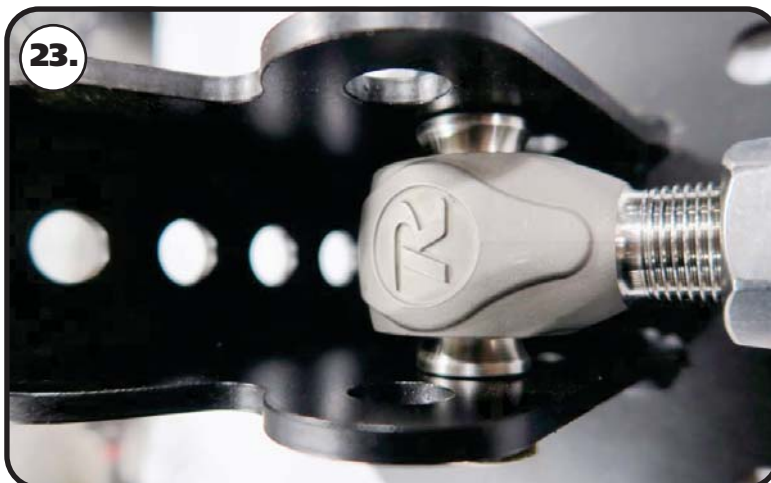

23. Image 23 shows a bottom view of the bar installed. Notice the spacers in each side of the R-Joint.



Setting Pinion Angle

READ PAGES 14-16 ON SETTING RIDE HEIGHT, SETTING PINION ANGLES & UPPER BAR TAB JIG INSTALLATION .

How do you set the pinion angle? On a single-piece shaft you want to set it up where a line drawn through the center of the engine crankshaft or output shaft of the transmission and a line drawn through the center of the pinion are parallel to each other but not the same line.

Your transmission angle should be around 3 degrees down in the rear. If it is more or less than 3 degrees, you might want to consider changing it. Too little angle on the transmission reduces the amount of oil getting to the rear bushing. Too much transmission angle will increase the working angles of the u-joints which will increase the wear. With the transmission at 3 degrees down in the rear, you will want to set the pinion 3 degrees up in the front.

A simple way to do this is to place a digital angle finder or dial level on the front face of the lower engine pulley or harmonic balancer. This will give you a reading that is 90 degrees to the crank or output shaft unless you have real problems with your balancer. At the other end, you can place the same level or angle finder against the front face of the pinion yoke that is also at 90 degrees to the centerline. If you rotate the yoke up or down so both angles match, you have perfect alignment.

Road testing will tell you if you have it right. If you accelerate and you get or increase a vibration, then the pinion yoke is too HIGH. Rotate it downward in small increments of a degree or two until the problem goes away. If you get or increase a vibration when decelerating, then the pinion yoke is too LOW. Rotate it upward to correct it.

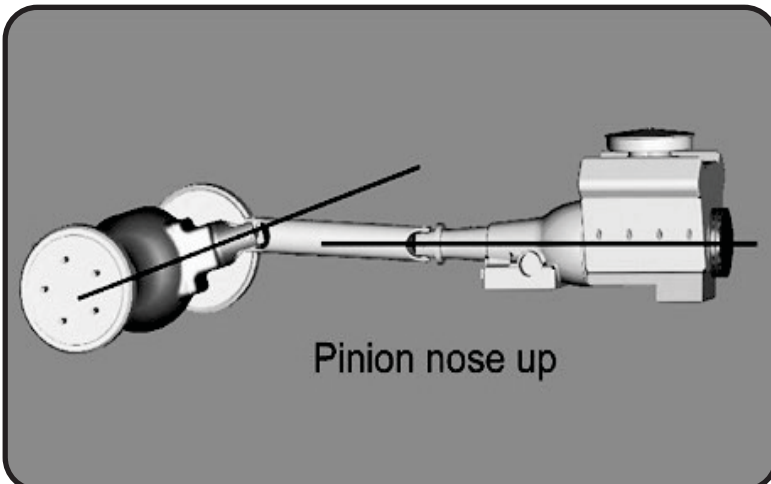
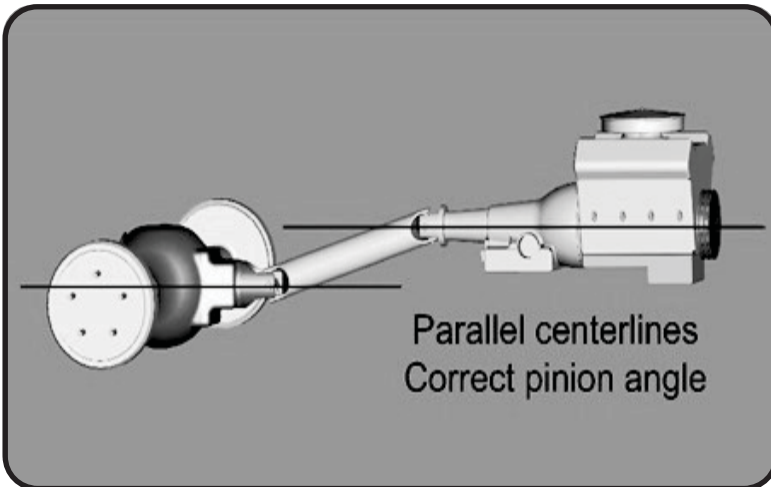
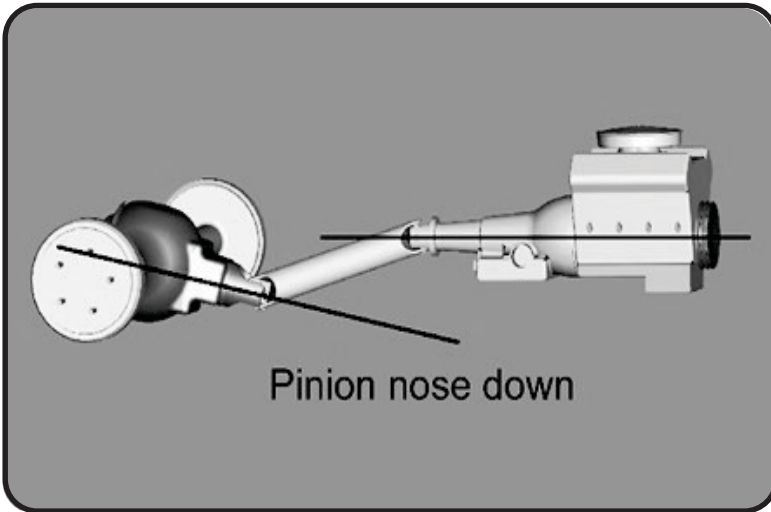



Upper Bar Tab Installation Jig

Upper Bar Installation Jig

- This jig has been supplied to aid in the installation of the upper 4 link bar. It can be temporarily used to properly align, locate and weld the tabs onto the axle. It will also ensure that the mounting bolts are parallel to the ground.
- Follow the diagram below to set the jig to the same length as the upper bar, use the 3/8" x 3/4" bolt and nuts to set the length.
- Position the axle at ride height. Center the axle left to right between the quarter panels. Set pinion angle.
- Bolt one end of the jig to the cradle using a 5/8" x 3" bolt.
- Using another 5/8" x 3" bolt, fasten the axle tabs to the other end. There is a Driver and Passenger Inner Tab. It is bent to keep the tab from hitting the center section of the rear end. It is positioned with the tab bent to the front of the car. The short tab goes to the outside of the car. The tabs must be bolted to the outside of the jig.
- Swing the bar down letting the tabs rest onto the axle. Trim the brackets as necessary to minimize the gap to be welded.
- Check pinion angle, ride height and axle center. Tack-weld the tabs in place and tack-weld the back brace in place. Refer to Images 25 & 26 for position of the back brace.
- Remove jig and install upper bar.
- Repeat this process for the other side.
- Recheck pinion angle, ride height and axle center. (Sound familiar?)
- After the tabs have been tack welded on both sides, remove the upper bars to avoid damaging the rod end. Let the axle drop down for better access to the tabs. Lay 1" welds on the inside and outside of the tabs. Skip around from one side to the other to avoid overheating the tube.

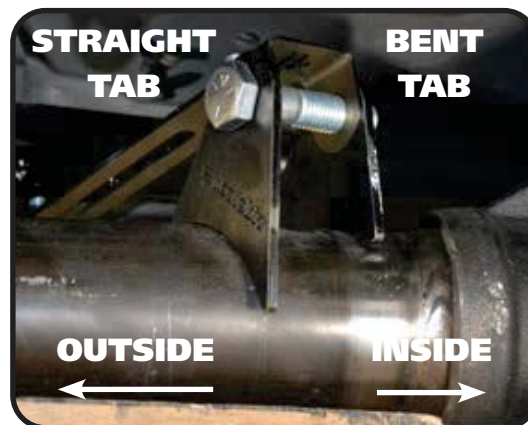
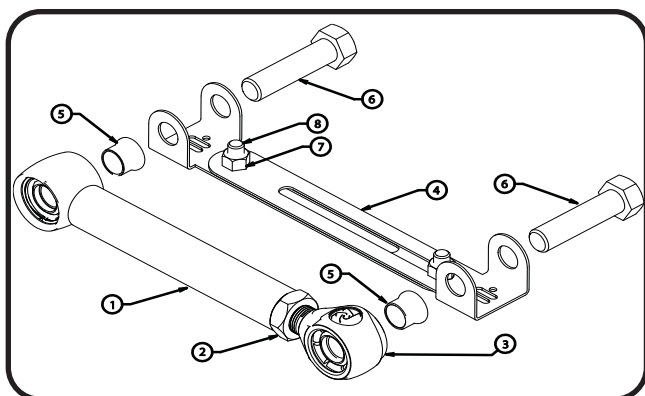

Item#	Description
1	Upper Bar
2	3/4"-16 Jam Nut
3	R-Joint End
4	Alignment Jig
5	Aluminum Spacer
6	5/8" x 2 3/4" Bolt
7	3/8"-16 Nut
8	3/8"-16 x 3/4" Bolt





Installing Axle Tabs



24. One helpful trick to help maintain ride height and pinion angle while adjusting is to tack weld a spacer between the axle and the outside of the frame as shown in the picture. This spacer should be 8 1/2" tall giving the Shockwave an eye-to-eye measurement of approximately 14 1/2". When measuring the axle center you can measure off of the frame rails. We also use a plum bob off the quarter panels to double check the axle center. Refer to **Page 14** on setting the pinion angle.

Note: You can tack weld the spacer in place after you get the pinion angle, and axle center set. This will ensure that nothing moves through the upper tab Installation.

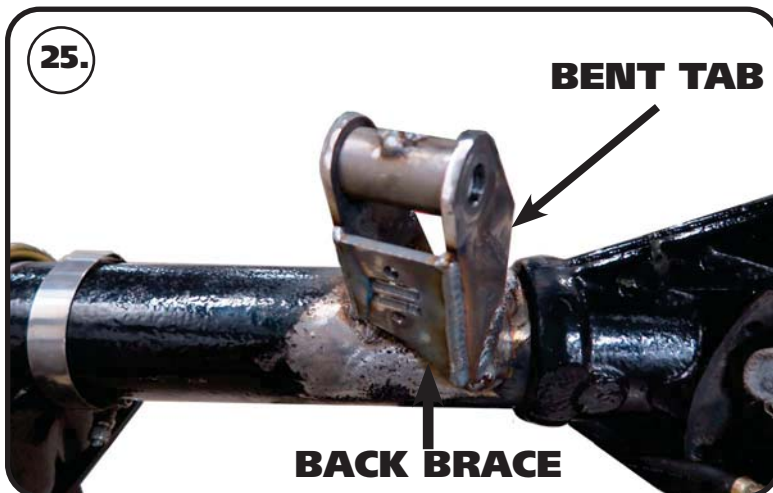

25. Check the length of the upper bar; it should be 10.150" center to center. Bolt the axle tabs to the setting jig as specified on the previous page. straight tab to the outside of the car, bent tab to the inside of the car. The bend needs to be to the front, making the front of the tab run parallel with the cast center section. If they are installed on the incorrect sides, the tab will hit the center section of the axle. Next, place the other end into the cradle. Both ends use a 5/8" x 3" and should not be fully tightened yet. For now just let axle tabs sit on the axle.

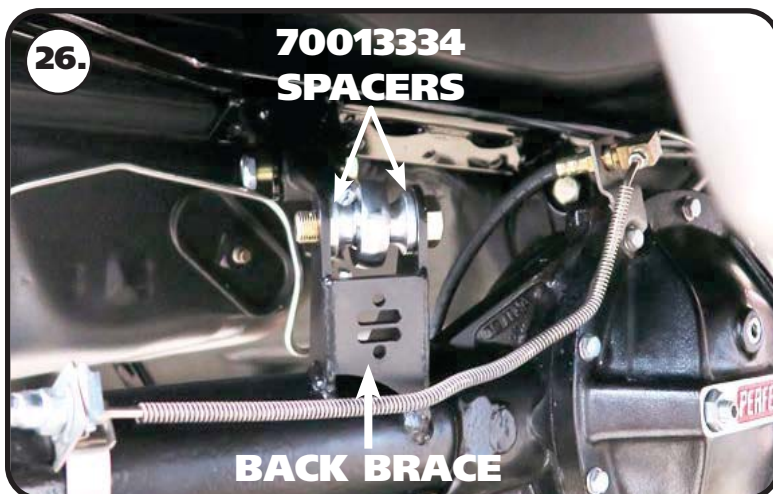

26. Check the fitment of the tabs and tack weld them to the axle. Do this for the Driver and Passenger side bars. Insert the bars into the cradle and tabs to double check fitment. Recheck axle center and pinion angle. Once satisfied with fitment weld the upper bar tabs onto the axle. Weld 1" at a time, skip around from one side to the other, and one tab to the other to avoid overheating the axle tube. When the tabs cool down, install the upper bars using (1) 5/8" x 3" bolt, (2) 5/8" flat washers, and (1) 5/8" Thin nylok nut on each end. Install a 70013334 spacer in each side of the R-joint using **Image 26** as a reference. Repeat on both sides and tighten the bolts/nuts enough to eliminate any gaps.



Installing Shockwaves/Coilovers & Shock Block Off

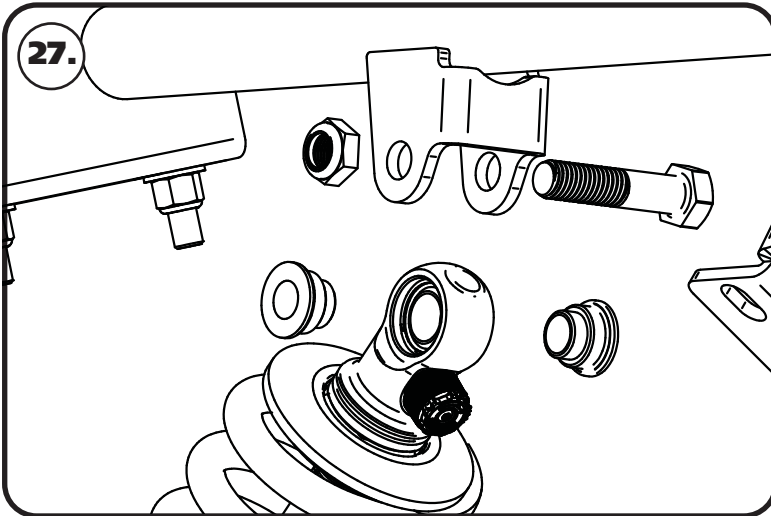

Remove the Spacer from between the Axle and Frame.

27. Install a 1/2" ID 90002043 spacer on each side of the upper Coilover/ShockWave. Slide the assembly into the upper crossmember from the bottom side. Position the adjuster knob so that the knob points toward the center of the car. Line up the hole in the spacers with the hole in the upper shock bridge and insert 1/2"-13 x 2 1/4" bolt and install 1/2"-13 Thin Nylok nut.

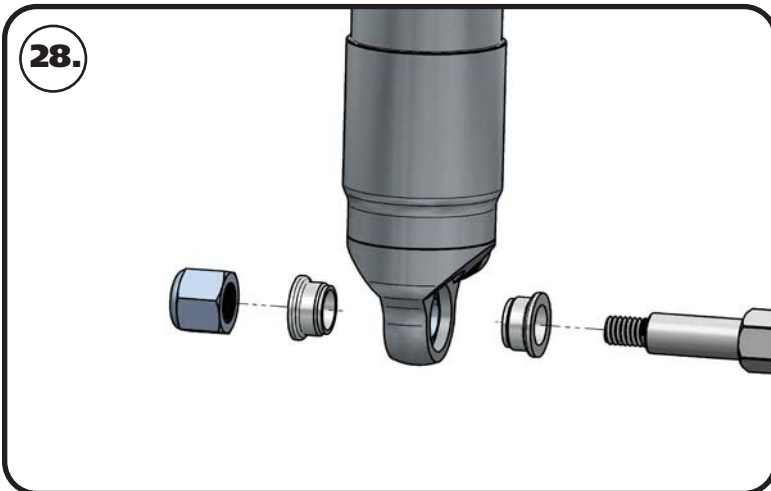

28. Install a 5/8" ID 90002067 spacer (**Small side towards shock body**) onto the lower Shock Stud. Slide the bottom of the Shock onto the Stud. Install a second 5/8" ID 90002067 Spacer onto the Stud (**small side towards shock**). You may need to jack the rearend up to Slide the Shock onto the Stud. Install the 7/16" Flat washer and 7/16" Nylok nut. Tighten the upper and lower shock bolts. Torque the Upper Bolt to 55 ftlbs and the Lower Nut to 40 ftlbs. The designed ride height of the CoilOver/Shockwave is 14 1/2" center to center.

Note: If installing Shockwaves and you want to locate the air fitting in a different location, the air spring assembly can be rotated on the shock by grabbing the air spring assembly by hand and spinning it on the shock.



29. Bolt the Shock Block Off Plates in place of the OEM upper shock mounts using the OEM hardware. If you are running Mini Tubs, these mounts do not exist any more.